

Backfeed protection for UPS systems

The advantages of an internal backfeed contactor



Introduction

The term 'backfeeding' refers to a situation where power is fed back towards the input terminals of an electrical device i.e. where the direction of power transfer is opposite to that of normal operation. This creates a safety hazard, since backfeeding of power may result in the input terminals being on power even if they have been disconnected from the mains supply. Backfeeding can also result in serious disturbances in other equipment connected at the common coupling point, and is often completely forbidden by network providers.

Backfeed protection in the UPS device shields the bypass line from static switch failure. The static switch is composed of antiparallel-connected thyristors. In the worst case, a thyristor failure may short circuit the entire internal bypass line of the UPS, therefore providing a low impedance path for a large amount of power.

Understanding backfeed protection requirements

The international standard IEC 62040-1 on 'General and safety requirements for UPS' requires that the UPS device shall prevent all hazardous voltage and energy from being transferred to the UPS input terminals after the input power has been interrupted.

The standard allows for two alternative implementations of backfeed protection: installing an internal backfeed isolation device within the UPS, or installing an external input line isolation device with only backfeed detection and control implemented within the UPS.

Backfeed protection in a single UPS system

Eaton 3-phase UPS equipment 9355, 9390 and 9395 include internal backfeed protection contactors as standard. Figure 1 shows the wiring diagram for a 275 kVA 9395 UPS with a K5 backfeed contactor. The rectifier and bypass input terminals are shown on the left side of the diagram and the UPS output terminals on the right.

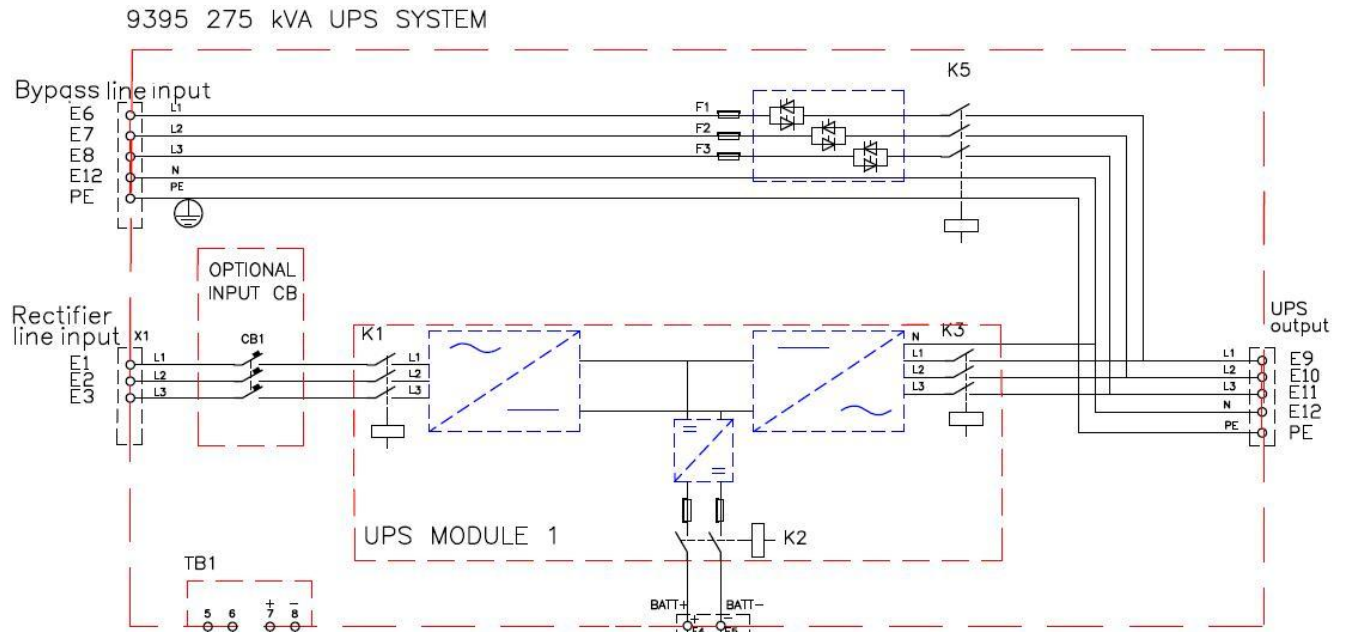

Figure 1: Wiring diagram of Eaton 9395 UPS with backfeed contactor (K5).

The internal backfeed contactor is used to automatically protect against fault situations within the static switch. If a thyristor in the static switch suffers a short-circuit failure, the inverter output to the bypass input terminal will also become shorted. This can result in a significant amount of power being drawn back towards the utility if the UPS is on power. The UPS firmware includes a backfeed-detection circuit, and the K5 backfeed contactor is used to clear the fault situation and automatically prevent the backfeeding of power. This enables the UPS to stay in double-conversion mode even in the case of a static switch failure.

The internal backfeed contactors in Eaton UPS units are always tested as part of the standard UPS manufacturing testing procedure. During the UPS burn-in tests:

- the UPS unit runs at 80% of its nominal power in both double-conversion and bypass modes
- current measurement accuracy of the static switch is tested
- the K5 contactor functionality is tested.

The bypass current measurement accuracy is important for backfeed protection, as it enables backfeed detection. When current is detected in the bypass line while the unit is not operating in bypass mode, the backfeed contactor opens automatically.

Backfeed protection in a parallel UPS system

UPSs are paralleled to gain higher availability or larger capacity in a UPS system. Backfeed protection is even more critical in parallel UPS systems as the size and power of the system are increased.

Figure 2 shows a block diagram example of a parallel UPS system with the internal backfeed contactors marked (K5).

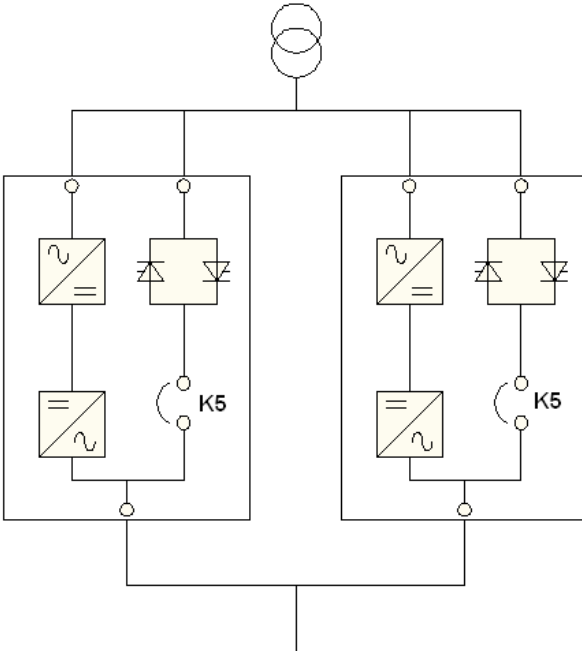

Figure 2: Parallel UPS system.

If a fault in one of the static switches were to occur, the paralleled inverters would start to provide current back to the mains, as indicated in Figure 3. In this situation, the backfeed contactor is opened automatically to prevent power being transferred back to the input transformer.

The static bypass lines of the parallel system have redundancy, since a failure of one static bypass does not prevent the other bypass lines from operating. In a redundant parallel system a static bypass failure does not affect the bypass capability of the system in any way; in capacity paralleled systems, however, the bypass rating would be slightly reduced.

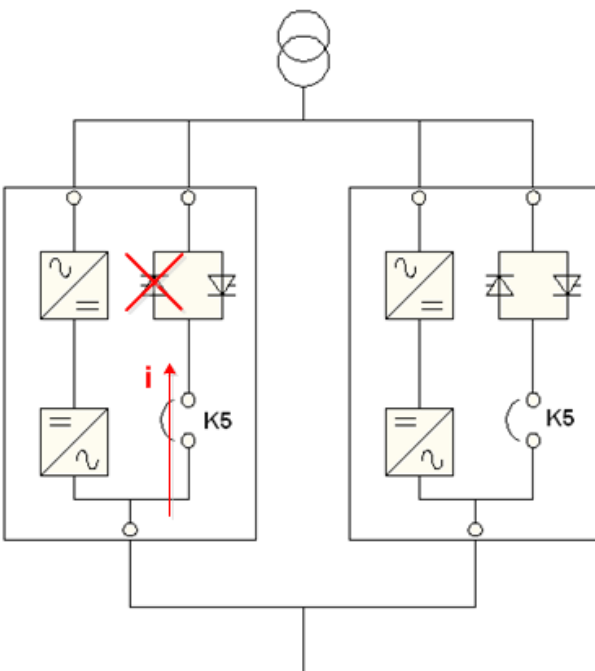

Figure 3: Parallel UPS system showing a fault in the static switch

Backfeed protection in a centralised bypass system

Some parallel UPS systems are constructed with centralised bypass topology, where the system bypass module (SBM) provides a common bypass line for all paralleled UPS units. A block diagram of this type of system is shown in Figure 4 below.

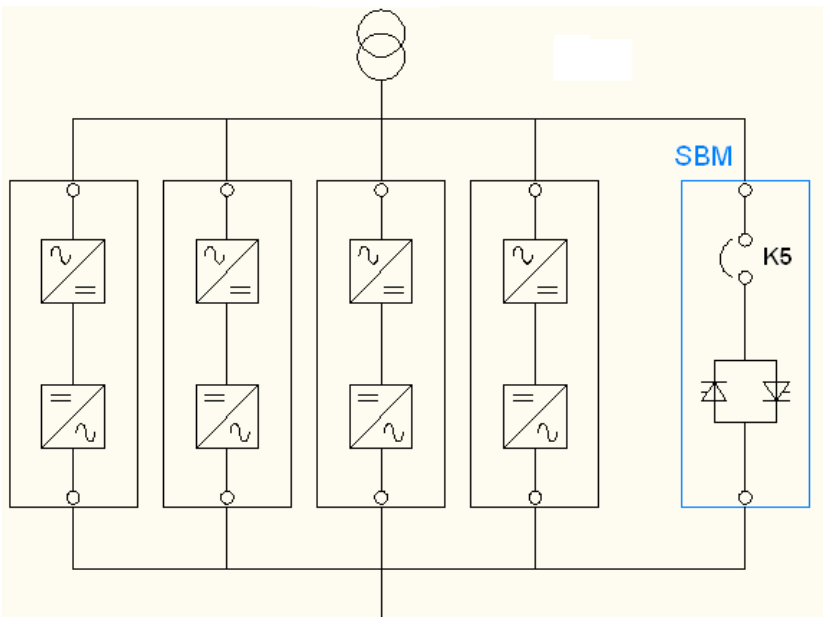

Figure 4: Parallel UPS system with SBM.

Similar to the UPS's internal bypass, the SBM also consists of antiparallel-connected thyristors. Therefore, backfeed protection is equally important in an SBM system. The Eaton SBM unit, which ranges from 2000-5000 A ratings, is presented in Figure 5. The SBM unit includes an internal backfeed disconnect device as standard.



Figure 5: The system bypass module (SBM).

Benefits of an internal backfeed contactor

As well as safety related advantages, internal backfeed protection in a UPS unit also brings operational advantages. One considerable advantage is the ability of the UPS to continue supplying power to critical loads in double-conversion mode even in the case of a static switch fault. In the event of a thyristor failure, the backfeed contactor opens automatically and the UPS unit can continue operating in double-conversion mode before, and even while maintenance work is carried out.

In a parallel UPS system, UPS internal backfeed protection means that each static switch in the distributed bypass system includes a backfeed contactor. Having an external backfeed contactor often means installing only one contactor for multiple static switches. In this case, therefore, a thyristor failure in one of the static switches results in the loss of all the static bypass lines connected to the common backfeed contactor.

Installing a backfeed contactor in the UPS as a standard feature enables the component to be tested simultaneously with the UPS equipment as a part of the standard manufacturing testing. This gives additional assurance in terms of demonstrating the reliability of the backfeed protection solution.

Especially when talking about UPS equipment in large power ranges, some UPS manufacturers only provide external backfeed contactors as an optional component. In this case the external backfeed contactor is installed in the system's input switchgear. This solution relies on backfeed protection isolation being planned, implemented and tested individually for each UPS installation, as none of these procedures would be performed by default.

About Eaton

Eaton Corporation is a diversified power management company with more than 100 years of experience providing energy-efficient solutions that help our customers effectively manage electrical, hydraulic and mechanical power. With 2011 sales of \$16.0 billion, Eaton is a global technology leader in electrical components, systems and services for power quality, distribution and control; hydraulics components, systems and services for industrial and mobile equipment; aerospace fuel, hydraulic and pneumatic systems for commercial and military use; and truck and automotive drivetrain and powertrain systems for performance, fuel economy and safety. Eaton has approximately 73,000 employees and sells products to customers in more than 150 countries. For more information, visit www.eaton.com.

Read more about Eaton's offering towards data centers at www.eaton.eu/datacenters.